

Part # GISB-A-24-37-25

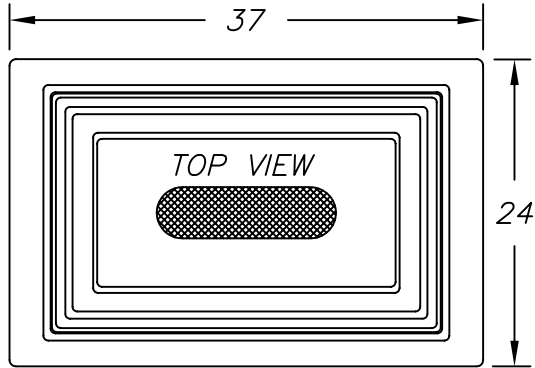

FLOW SCHEMATIC

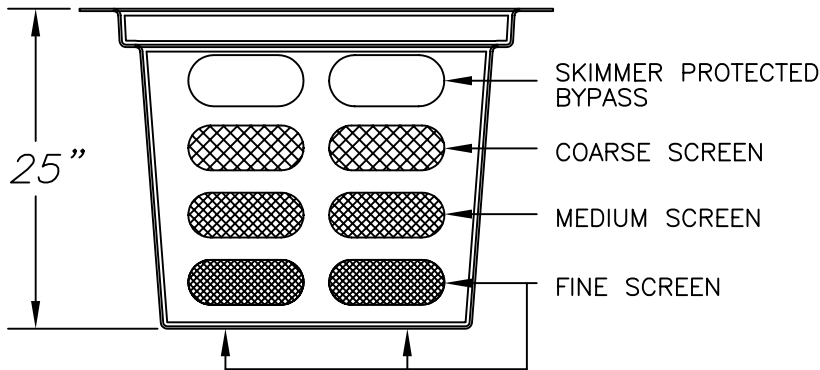
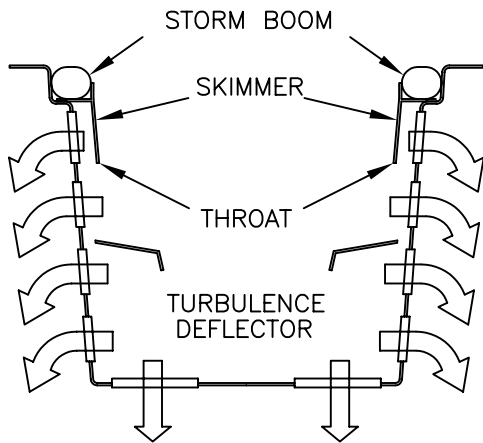

SIDE VIEW

Flow Specifications				
Description of filter opening	Percent Open Based on Screen Dimensions	Total Square Inches per Unit	Square Inches of Total Unobstructed Openings	Flow Rate (Cubic Feet per Second)
Skimmer protected By-Pass	100%	211.4	211.4	8.7 cfs
Coarse Screen 3/4" x 1-3/4" stainless steel flattened expanded	62%	187.2	116.1	5.6 cfs
Medium Screen 10x10 mesh stainless steel	56%	187.2	104.9	5.7 cfs
Fine screen 14 x 18 mesh stainless steel	68%	239.8	163.1	9.8 cfs
THROAT FLOW RATE Total: 10.2 cfs		TREATED FLOW RATE Total: 21.1 cfs		
FLOW RATES BASED ON UNOBSTRUCTED OPENINGS				

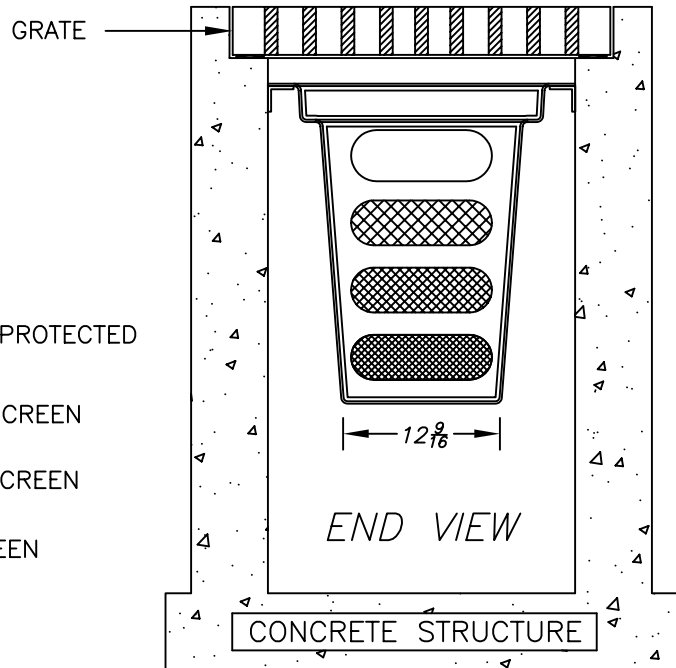

END VIEW

BOX MANUFACTURED FROM
MARINE GRADE FIBERGLASS & GEL
COATED FOR UV PROTECTION
5 YEAR MANUFACTURERS WARRANTY

PATENTED

ALL FILTER SCREENS ARE STAINLESS STEEL

MOUNT TO WALL BELOW
GRATE WITH MOUNTING KIT
CONSISTING OF ALUMINUM
ANGLES, TAPCONS, AND DRILL BITS
MOUNTING KIT
SOLD SEPARATELY

EXCLUSIVE CALIFORNIA DISTRIBUTOR:
BIO CLEAN ENVIRONMENTAL SERVICE
P.O. BOX 869, OCEANSIDE, CA. 92049
TEL: 760-433-7640 FAX: 760-433-3176
Email: info@biocleanenvironmental.net

SUNTREE QUALITY PRODUCTS ARE BUILT FOR EASY CLEANING AND ARE
DESIGNED TO BE PERMANENT INFRASTRUCTURE AND SHOULD
LAST FOR DECADES.

SUNTREE TECHNOLOGIES 798 CLEARLAKE RD, SUITE #2 COCOA FL. 32922 TEL. 321-637-7552 FAX 321-637-7554		PROJECT:	
GRATE INLET SKIMMER BOX FOR FLORIDA DOT TYPE A INLET STRUCTURES.		REVISIONS:	DATE:
DATE: 04/12/04	SCALE: SF = 15	REVISIONS:	DATE:
DRAFTER: N.R.B.	UNITS = INCHES	REVISIONS:	DATE: